

## SCHOTTKY BARRIER RECTIFIER

### Features

- ◆ The plastic package carries Underwriters Laboratory Flammability Classification 94V-0
- ◆ Construction utilizes void-free molded plastic technique
- ◆ Low reverse leakage
- ◆ High forward surge current capability
- ◆ High temperature soldering guaranteed: 250°C, 0.25" (6.35mm) from case for 10 seconds

**TO-220AB**

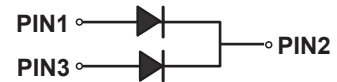
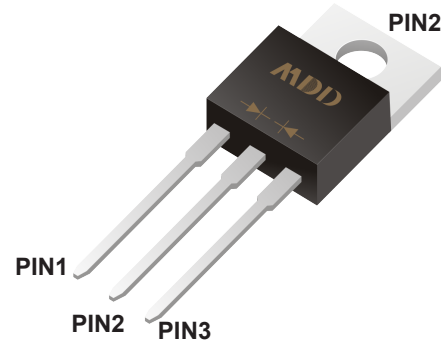

### Mechanical Data

**Case** : JEDEC TO-220AB Molded plastic body  
**Terminals** : Solder plated, solderable per MIL-STD-750, Method 2026  
**Polarity** : Polarity symbol marking on body  
**Mounting Position** : Any  
**Weight** : 0.060 ounce, 1.67 grams

### Maximum Ratings And Electrical Characteristics

Ratings at 25°C ambient temperature unless otherwise specified.

Single phase half-wave 60Hz, resistive or inductive load, for capacitive load current derate by 20%.

Parameter	SYMBOLS	MDD	MDD	MDD	MDD	MDD	UNITS
		MBR	MBR	MBR	MBR	MBR	
Marking Code		1045CT	1060CT	10100CT	10150CT	10200CT	
Maximum repetitive peak reverse voltage	$V_{RRM}$	45	60	100	150	200	V
Maximum RMS voltage	$V_{RMS}$	32	42	70	135	140	V
Maximum DC blocking voltage	$V_{DC}$	45	60	100	150	200	V
Maximum average forward rectified current (see fig.1)	$I_{(AV)}$	10.0					A
Peak forward surge current 8.3ms single half sine-wave superimposed on rated load (JEDEC Method)	$I_{FSM}$	150			125		A
Maximum instantaneous forward voltage at 5.0A	$V_F$	0.60	0.75	0.85	0.95		V
Maximum DC reverse current at rated DC blocking voltage $T_A=25^\circ C$ $T_A=100^\circ C$	$I_R$	1.0			0.1		mA
		15.0	50.0		15.0		
Typical thermal resistance (NOTE 2)	$R_{\theta JC}$	2.0			1.5		$^\circ C/W$
Operating junction temperature range	$T_J$	-55 to +150					$^\circ C$
storage temperature range	$T_{STG}$	-55 to +150					$^\circ C$

**Note:** 1. Measured at 1MHz and applied reverse voltage of 4.0V D.C.

2. Thermal resistance from junction to case.

## Ratings And Characteristic Curves

Fig.1 Typical Forward Current Derating Curve

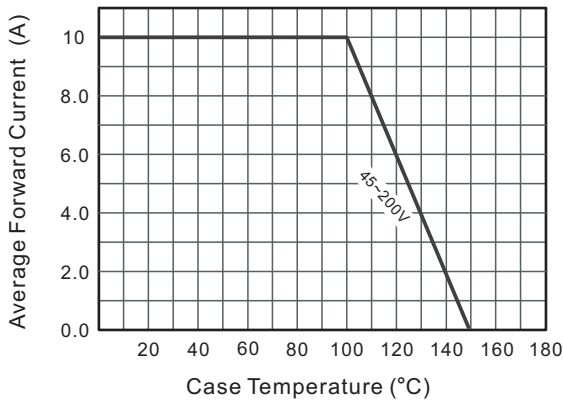

Fig.2 Typical Reverse Characteristics

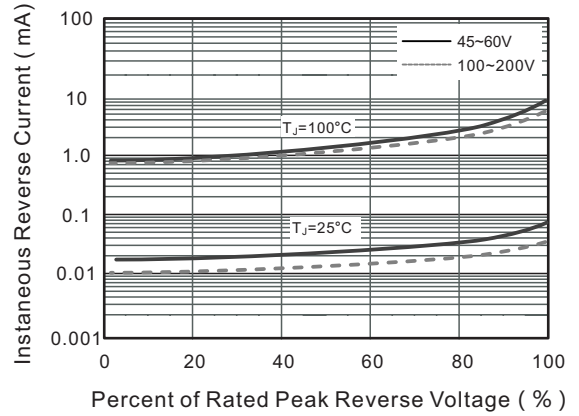

Fig.3 Typical Forward Characteristic(per leg)

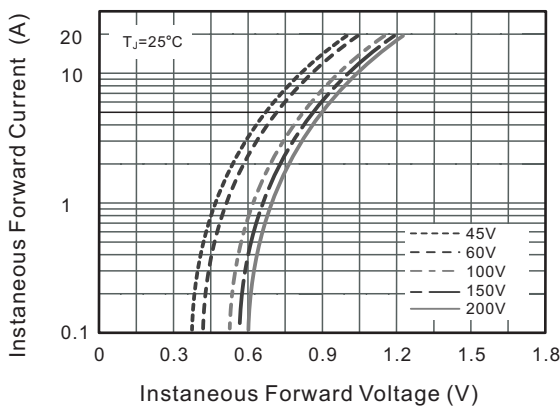
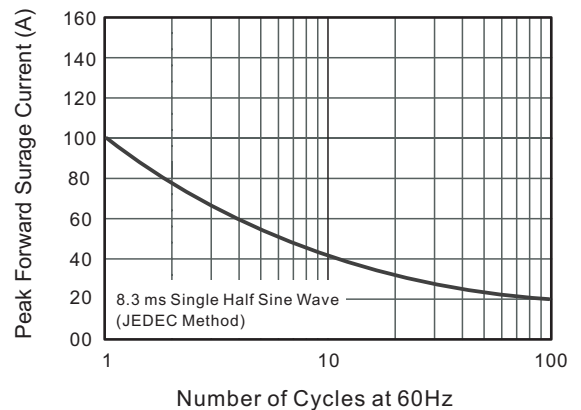

Fig.4 Maximum Non-Repetitive Peak Forward Surge Current



The curve above is for reference only.

## Outline

### TO-220AB Package Outline Dimensions

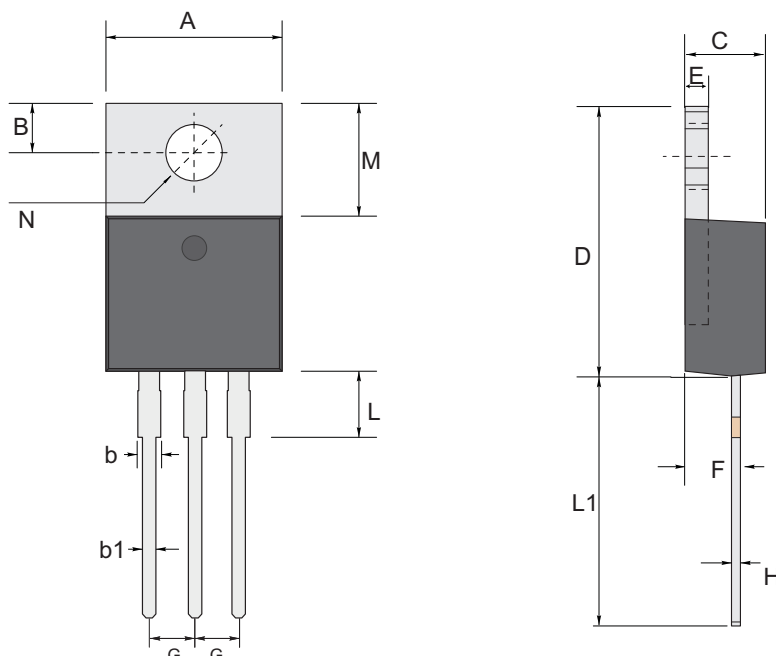

### TO-220AB mechanical data

UNIT		A	B	b	b1	C	D	E	F	G	H	L	L1	M	N
mm	max	10.45	2.94	1.77	0.94	4.76	16.0	1.40	2.90	2.54 TYPICAL	0.64	4.2	14.79	6.60	3.86
	min	9.85	2.54	1.14	0.62	4.42	14.6	1.14	2.20		0.35	2.8	13.00	6.13	3.8

## Important Notice and Disclaimer

Microdiode Electronics (Shenzhen) reserves the right to make changes to this document and its products and specifications at any time without notice. Customers should obtain and confirm the latest product information and specifications before final design, purchase or use.

Microdiode Electronics (Shenzhen) makes no warranty, representation or guarantee regarding the suitability of its products for any particular purpose, nor does Microdiode Electronics (Shenzhen) assume any liability for application assistance or customer product design. Microdiode Electronics (Shenzhen) does not warrant or accept any liability with products which are purchased or used for any unintended or unauthorized application.

No license is granted by implication or otherwise under any intellectual property rights of Microdiode Electronics (Shenzhen).

Microdiode Electronics (Shenzhen) products are not authorized for use as critical components in life support devices or systems without express written approval of Microdiode Electronics (Shenzhen).